



### Description

The GORA Sliding Sleeve is a communication device with a ported inner sleeve that can be opened or closed using a shifting tool by standard slickline or coiled tubing methods. Equalizing holes in the inner sleeve provide pressure equalization between the tubing and casing annulus as the sleeve is opened. The Sliding Sleeve is made up to and forms part of the tubing string. The GORA Sliding Sleeve is a shift-up-to-open tool.

The GORA Sliding Sleeve uses common machined parts that allow the shift-open direction to be changed from up-to-open to down-to-open by simply substituting different sub ends

The GORA Sliding Sleeve is used to establish a means of communication between the tubing string and the casing annulus for single-tubing or multiple-tubing string completions. The GORA Sliding Sleeve may be used for directing flow from the casing to the tubing in alternate or selective completions. Other applications include killing a well, spot acidizing and fracturing, or equalizing pressure between an isolated formation and the tubing string.

### Features and Benefits

- Compact and simple field proven design, that is cost effective and reliable, with a long operating life.
- Manufactured standard in 4140 18-22Rc Alloy Steel with Viton elastomers for Standard and H2S Service.
- GOR Selective Nipple Profile to land slickline tools. (Comparable to Halliburton's R<sup>®</sup> Landing Nipple Profile).

### Technical Numbers and Accessory Info

- **Maximum OD:** Coupling OD is standard, but OD can be larger, or smaller upon request.
- **Minimum ID:** Seal Bores.
- **Opening Direction:** UP
- **Drift Diameter:** 0.0010" to 0.0015" smaller than seal bore Minimum ID.
- **Shifting Tools:** Otis "B", Otis "BO", and DFAST
- **Separation Sleeve:** GRS
- **Blanking Plug:** GPR
- **Standing Valve:** GVR

### Testing

All GORA Sliding Sleeves are pressure tested to 6,000 psi using internal seal bore seals that pressure test both the seal stacks and the seal bores.

As previously noted, GORA Sliding Sleeves are shifted with Otis type "B" shifting tools, for testing purposes, a shifting tool dressed with self-releasing keys is used; shear to release keys can also be used.

Sliding Sleeves-Landing Nipples-Blanking Plugs-Shifting Tools-On/Off Tools-Completion Packers  
Flow Couplings/Blast Joints-Pup Joints-Crossover Subs-Jet Pumps-Anchor Catchers-Shear Out Safety Joints-Tubing  
Drains-Much Much More.

Ph: 403-279-2015 Fax: 403-279-2019 [www.giantoiltools.com](http://www.giantoiltools.com) sales@giantoiltools.com



Depending on the amount of squeeze applied to the V-Rings after assembling the sliding sleeve, the shifting force required to open and close the sliding sleeve may vary, therefore a steel pin is used inside the shifting tool to stop premature shearing of the pin before the sliding sleeve has been fully opened or closed.

1. After fully assembling the sliding sleeve, tighten it in a vise horizontally and shift the sliding sleeve closed-open-closed, verifying that the sliding sleeve is fully closed and open each time.
2. Insert the test plugs into either end of the sliding sleeve; you will feel the seals grab the seal bores, confirming location.
3. Fill the Sliding Sleeve with water or hydraulic fluid and apply pressure up to 500 psi.
4. Apply pressure in 1,000 psi increments, pausing every 1,000 psi for 5 seconds; up to 6,000 psi.
5. Hold at 6,000 psi for 10 minutes, ensure there are no leaks and drop in pressure, engrave the sliding sleeve with a pressure test serial number and mark the pressure test chart with the same serial number.
6. Bleed off pressure, shift the sliding sleeve open-closed to ensure functionality and tighten sliding sleeve body connections, wipe down and store.

### Operating

When one or more GORA Sliding Sleeves are run on the same production string, different slickline tool strings might be required to selectively open or close the Sliding Sleeve depending on which Sliding Sleeve is to be opened or closed first.

In the GORA Sliding Sleeve, there is an open, equalized, and closed position. The equalized position allows differential pressure across the Sliding Sleeve to equalize prior to the final full open position and prevent the full force of the differential pressure from acting on the v-seal stacks.

### Opening a GORA Sliding Sleeve

**Important Note:** *When opening a GORA Sliding Sleeve, ensure that there is minimal to no differential pressure across the Sliding Sleeve. Differential pressure across the Sliding Sleeve from the annulus to tubing or tubing to annulus could cause damage to the seals of the sliding sleeve.*

1. With the keys facing upward, attach the Otis "B" shifting tool to the slickline tool string. Lower the slickline tool string in the tubing until below the Sliding Sleeve. Move the slickline tool string upward until the keys engage in the Upper recess of the Inner Sleeve.
2. Jar upward until the pressure across the Sliding Sleeve starts to equalize.
3. Once the pressure across the Sliding Sleeve has equalized, continue to jar upward until the Inner Sleeve is completely shifted, fully opening the Sliding Sleeve.
4. Continue jarring upward until the inclined shoulder of the Sliding Sleeve forces the keys inward, allowing the shifting tool to pass through the sleeve.

Sliding Sleeves-Landing Nipples-Blanking Plugs-Shifting Tools-On/Off Tools-Completion Packers  
Flow Couplings/Blast Joints-Pup Joints-Crossover Subs-Jet Pumps-Anchor Catchers-Shear Out Safety Joints-Tubing  
Drains-Much Much More.

Ph: 403-279-2015 Fax: 403-279-2019 [www.giantoiltools.com](http://www.giantoiltools.com) sales@giantoiltools.com



## Model GORA Sliding Sleeve

Assembly & Testing Technical Information

Part Number: (Various)

5. Before returning the shifting tool to the surface, run it back through the Sliding Sleeve several times to ensure the Inner Sleeve is in the open position.

### Closing a GORA Sliding Sleeve

1. With the keys facing downward, attach the Otis "B" shifting tool to the slickline tool string. Run the slickline tool string in the tubing until the keys of the shifting tool lock in the Lower recess of the Inner Sleeve.
2. Jar downward until the Inner Sleeve is completely shifted, placing the Sliding Sleeve in the closed position.
3. Continue jarring downward until the inclined shoulder of the Sliding Sleeve forces the keys of the shifting tool inward, disengaging it from the recess of the Inner Sleeve, and allow the shifting tool to pass through the sliding sleeve.
4. Before returning the shifting tool to the surface, run it back through the Sliding Sleeve several times to ensure the Inner Sleeve is in the closed position.

Sliding Sleeves-Landing Nipples-Blanking Plugs-Shifting Tools-On/Off Tools-Completion Packers  
Flow Couplings/Blast Joints-Pup Joints-Crossover Subs-Jet Pumps-Anchor Catchers-Shear Out Safety Joints-Tubing  
Drains-Much Much More.

Ph: 403-279-2015 Fax: 403-279-2019 [www.giantoiltools.com](http://www.giantoiltools.com) sales@giantoiltools.com



# Model GORA Sliding Sleeve

Assembly & Testing Technical Information

Part Number: (Various)

Giant Oil Tools Ltd., Model GORA Sliding Sleeve										
*Seal Bore ID		**Flow Area (Ports)		Flow Area (Min ID)		Max OD		Thread Box x Pin	Shifting Tool	***Max Working Pressure (psi)
in.	mm.	Sq in.	Sq cm.	Sq in.	Sq cm.	in.	mm.			
1.375	34.65	0.919	5.93	1.484	9.58	2.375	60.33	1.900 NUE	1.250 "B"	8,000
1.500	37.80			1.766	11.40	2.625	66.68	2-1/16" IJ	1.500 "B"	
1.625	40.95	1.168	29.67	2.073	13.37	3.063	77.80	2-3/8" EUE	1.625 "B"	9,000
1.710	43.09	2.355	15.19	2.295	14.81					
1.875	47.25			2.762	17.82					
2.125	53.55	3.974	25.64	3.545	22.87	3.750	95.25	2-7/8" EUE	2.125 "B"	
2.188	55.14			3.758	24.25	3.900	99.06		2.312 "B"	
2.312	58.26			4.199	27.09					
2.562	64.56	7.212	46.53	5.153	33.24	4.620	117.35	3-1/2" EUE	2.562 "B"	7,500
2.750	69.30			5.940	38.32					
2.812	70.86			6.211	40.07					
2.875	72.45			6.489	41.86					
3.125	78.75	11.426	73.72	7.666	49.46	5.815	147.70	4-1/2" EUE	2.875 "B"	6,500
3.312	83.46			8.611	55.55				3.125 "B"	
3.437	86.61			9.273	59.83				3.313 "B"	
3.688	92.94			10.677	68.88				3.437 "B"	
3.812	96.06			11.413	73.63				3.688 "B"	
4.125	103.95	10.598	68.37	13.357	86.18	6.400	162.56	5-1/2" BTC	3.812 "B"	
4.312	108.66			14.596	94.17				4.125 "B"	
4.562	114.96			16.337	105.40				7.500	
									4.562 "B"	

\*Seal Bore ID is also the Minimum ID of the Sliding Sleeve.

\*\*Flow Area thru ports is available equal to Min ID upon request.

\*\*\*HIGHER PRESSURE RATINGS AVAILABLE UPON REQUEST.

Sliding Sleeves-Landing Nipples-Blanking Plugs-Shifting Tools-On/Off Tools-Completion Packers  
 Flow Couplings/Blast Joints-Pup Joints-Crossover Subs-Jet Pumps-Anchor Catchers-Shear Out Safety Joints-Tubing  
 Drains-Much Much More.

Ph: 403-279-2015 Fax: 403-279-2019 [www.giantoiltools.com](http://www.giantoiltools.com) sales@giantoiltools.com

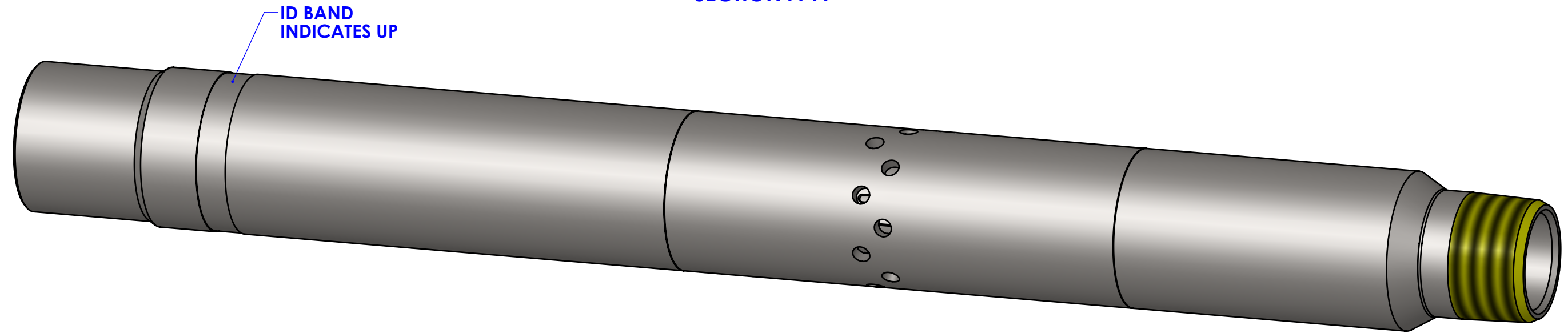
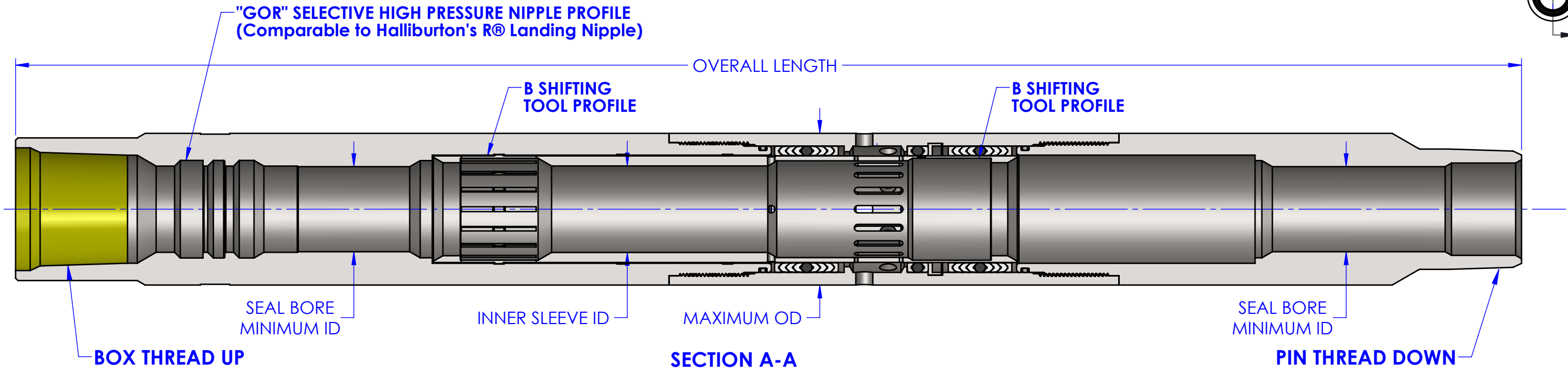
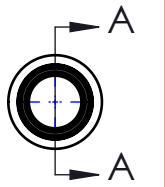

**SHIFT-UP-TO-OPEN  
SHIFTING TOOL: B or DFAST**

MATERIAL -	UNLESS OTHERWISE SPECIFIED TOLERANCES .X = ± 0.030 .XX = ± 0.015 .XXX = ± 0.005 FRACTIONS = ± 1/64 ANGLES = ± 1/2° INSIDE CORNERS 0.015 R. MAX. ALL THREAD ENTRY AND EXIT ANGLES TO BE 45° OFF AXIS OF THREAD REMOVE ALL BURRS AND SHARP CORNERS ALL THREADS—RIGHT HAND	SURFACE FINISH 125 ✓		GIANT OIL TOOLS	DRAWN -	DATE -
					APPROVED -	DATE -
HEAT TREATMENT			DWG NO.	-		
COATING -			DESCRIPTION	GORA SLIDING SLEEVE		
UPPER END ← LOWER END → (ID) = IDENTIFICATION	UNITS INCHES		PROJECT	-		
CONFIDENTIAL AND TRADE SECRET. DO NOT DISCLOSE, USE OR REPRODUCE WITHOUT WRITTEN APPROVAL FROM G.O.T.			SCALE NTS	SHT. OF 1 1	PART REV. -	DWG REV. -
				MASS -	LB	